

**General Description**

Cartridge Style Check Valve.  
 For additional information see Technical Tips on pages CV2-CV3.

**Features**

- Hardened, precision ground parts for durability
- Fully guided poppet for smooth operation
- All external parts zinc plated

**Performance Curve**

Pressure Drop vs. Flow (Through cartridge only)

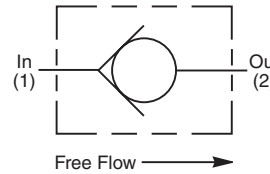
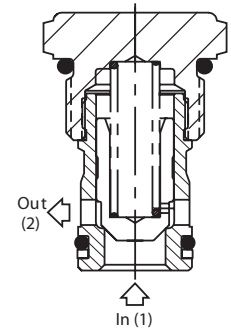
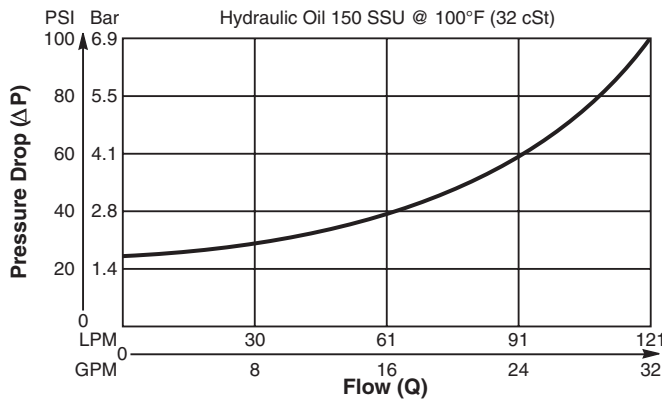

**Dimensions** Millimeters (Inches)

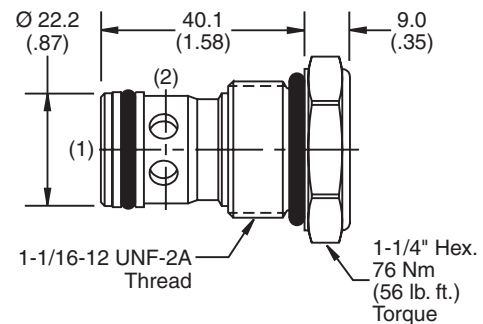

**Specifications**

Rated Flow	121 LPM (32 GPM)
Maximum Inlet Pressure	350 Bar (5000 PSI)
Leakage at 150 SSU (32 cSt)	5 drops/min. (0.33 cc/min) at 350 Bar (5000 PSI)
Cartridge Material	All parts steel. All operating parts hardened steel.
Operating Temp. Range/Seals	-34°C to +121°C (Nitrile) (-30°F to +250°F) -26°C to +204°C (Fluorocarbon) (-15°F to +400°F)
Fluid Compatibility/Viscosity	Mineral-based or synthetic with lubricating properties at viscosities of 45 to 2000 SSU (6 to 420 cSt)
Filtration	ISO-4406 18/16/13, SAE Class 4
Approx. Weight	0.14 kg (0.30 lbs.)
Cavity	C12-2 (See BC Section for more details)

**Ordering Information**

**CVH121P**

12 Size  
 Check Valve

**Highlighted** represents preferred options that offer the shortest lead times. Other options may be available, but at extended lead times.

Code	Cracking Pressure
Omit	1.7 Bar (25 PSI)

Code	Seals
Omit	Nitrile

Kit	Part Number
Nitrile Seal	SK12-2
Fluorocarbon Seal	SK12-2V

Order Bodies Separately  
 See section BC

<b>B12</b>	—	<b>2</b>	—	<b>12T</b>
12 size		2-Way Cavity		Port Size

Code	Porting / Body Material
12T	SAE-12 / Steel (5000 PSI)

<b>CV</b> Check Valves
<b>SH</b> Shuttle Valves
<b>LM</b> Load/Motor Controls
<b>FC</b> Flow Controls
<b>PC</b> Pressure Controls
<b>LE</b> Logic Elements
<b>DC</b> Directional Controls
<b>SV</b> Solenoid Valves
<b>PV</b> Proportional Valves
<b>CE</b> Coils & Electronics
<b>BC</b> Bodies & Cavities
<b>TD</b> Technical Data